

# NO GOOD GOFERS (50061)

## FUSE LIST

### POWER DRIVER BOARD

F101	Regulated 12V	T0.63A, 250V
F102	Solenoids #9 to #16	T4.0A, 250V
F103	Solenoids #1 to #8	T4.0A, 250V
F104	Solenoids #25 to #28	T4.0A, 250V
F105	+5V Logic	T4.0A, 250V
F106	+18V Lamp Matrix	T5.0A, 250V
F107	Flasher Secondary	T4.0A, 250V
F108	Solenoid Secondary	T6.3A, 250V
F109	Unregulated 12V	T4.0A, 250V
F110	G.I. #5 White-Violet	T4.0A, 250V
F111	G.I. #4 White-Green	T4.0A, 250V
F112	G.I. #3 White-Yellow	T4.0A, 250V
F113	G.I. #2 White-Orange	T4.0A, 250V
F114	G.I. #1 White-Brown	T4.0A, 250V
F115	+50V Flippers	T4.0A, 250V
F116	+50V Flippers	T4.0A, 250V
F117	+50V Flippers	T4.0A, 250V
F118	+50V Flippers	T4.0A, 250V

CAUTION: FOR CONTINUED PROTECTION AGAINST RISK OF FIRE, REPLACE ONLY WITH THE SAME TYPE OF FUSE HAVING THE SAME ELECTRICAL RATINGS.

### AUDIO/VIDEO BOARD

F501	-25V	T2.5A, 250V
F502	+25V	T2.5A, 250V
F601	+62V	T0.25A, 250V
F602	-113V & -125V	T0.25A, 250V

### LINE FILTER

Foreign	T4.0A, 250V
Domestic	T5.0A, 250V

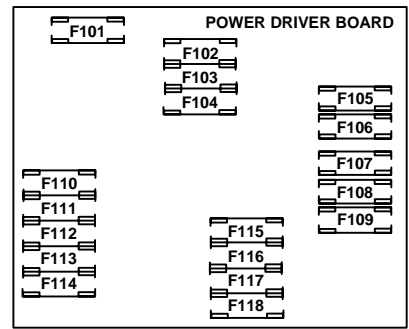
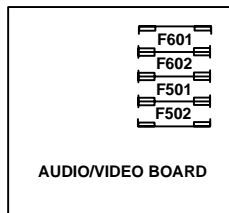

## SOLENOID/FLASHER TABLE

Sol No.	Function	Solenoid Type	Voltage Connections			Drive Xistor	Drive Connections			Drive Wire Color	Solenoid/Flashlamp	
			Playfield	Backbox	Cabinet		Playfield	Backbox	Cabinet		Playfield	Backbox
01	AUTO FIRE	High Power	J133-2			Q72	J116-1			VIO-BRN	AE-23-800	
02	KICKBACK	High Power	J133-2	J134-3		Q68	J116-2			VIO-RED	AE-23-800	
03	CLUBHOUSE KICKER	High Power	J133-2			Q71	J116-4			VIO-ORG	AE-23-800	
04	LEFT GOFER UP	High Power	J133-2			Q67	J116-5			VIO-YEL	LE-22-925	
05	RIGHT GOFER UP	High Power	J133-2			Q70	J116-6			VIO-GRN	LE-22-925	
06	JET POPPER	High Power	J133-2			Q66	J116-7			VIO-BLU	AE-27-1200	
07	LEFT EJECT	High Power	J133-2			Q69	J116-8			VIO-BLK	AE-24-900	
08	UPPER RIGHT EJECT	High Power	J133-2			Q65	J116-9			VIO-GRY	AE-27-1200	
09	TROUGH EJECT	Low Power	J133-3			Q44	J113-1			BRN-BLK	AE-26-1500	
10	LEFT SLINGSHOT	Low Power	J133-3			Q48	J113-3			BRN-RED	AE-27-1200	
11	RIGHT SLINGSHOT	Low Power	J133-3			Q43	J113-4			BRN-ORG	AE-27-1200	
12	TOP JET BUMPER	Low Power	J133-3			Q47	J113-5			BRN-YEL	AE-26-1200	
13	MIDDLE JET BUMPER	Low Power	J133-3			Q42	J113-6			BRN-GRN	AE-26-1200	
14	BOTTOM JET BUMPER	Low Power	J133-3			Q46	J113-7			BRN-BLU	AE-26-1200	
15	LEFT GOFER DOWN	Low Power	J133-3			Q41	J113-8			BRN-VIO	AE-30-2000	
16	RIGHT GOFER DOWN	Low Power	J133-3			Q45	J114-9			BRN-GRY	AE-30-2000	
17	JET FLASHER	Flasher	J133-6			Q28	J111-1			BLK-BRN	#906	
18	LOWER LEFT FLASHER	Flasher	J133-6			Q32	J111-2			BLK-RED	#906	
19	LEFT SPINNER FLASHER	Flasher	J133-6			Q27	J111-3			BLK-ORG	#906	
20	RIGHT SPINNER FLASHER	Flasher	J133-6			Q31	J111-4			BLK-YEL	#906, #89	
21	LOWER RIGHT FLASHER	Flasher	J133-2			Q26	J111-5			BLU-GRN	#89	
22	NOT USED	Flasher				Q30				BLU-BLK		
23	NOT USED	Flasher				Q25				BLU-VIO		
24	UNDERGROUND PASS	Flasher	J133-1			Q29	J111-8			BLU-GRY	AE-27-1200	
25	SAND TRAP FLASHER	Gen. Purpose	J133-6			Q16	J109-1			BLU-BRN	#906 (2)	
26	WHEEL FLASHER	Gen. Purpose	J133-6			Q15	J109-2			BLU-RED	#906	
27	LEFT RAMP DOWN	Gen. Purpose	J133-1			Q14	J109-3			BLU-ORG	SM1-28-900	
28	RIGHT RAMP DOWN	Gen. Purpose	J133-1			Q13	J109-4			BLU-YEL	SM1-28-900	

### General Illumination

01	LEFT SIDE STRING	G.I.	J105-1			Q5	J105-7			WHT-BRN	#555, #545	
02	RIGHT SIDE STRING	G.I.	J105-2			Q4	J105-8			WHT-ORG	#555, #545	
03	GOFER SPOTLIGHT	G.I.	J105-3			Q3	J105-9			WHT-YEL	#44	#555
04	*ILLUMINATION STRING 4	G.I.		J106-5		Q2		J106-10		WHT-GRN	#44	
05	*ILLUMINATION STRING 5	G.I.		J106-6	J104-3	Q1		J106-11	J104-1	WHT-VIO	#44	

### Flipper Circuits

Sol No.	Function	Solenoid Type	Voltage Connection		Drive Xistors		Drive Connections		Drive Wire Colors		Coil Part No.	Coil Colors
			Playfield	Backbox	Power	Hold	Playfield	Backbox	Power	Hold		
29	LOWER RIGHT FLIPPER	Power	J119-1 (RED-GRN)		Q90		J120-13		YEL-GRN		FL-11629	BLUE
30	LOWER RIGHT FLIPPER	Hold	J119-1 (RED-GRN)			Q92	J120-11		ORG-GRN			
31	LOWER RIGHT FLIPPER	Power	J119-4 (RED-BLU)		Q67		J120-9		YEL-BLU		FL-11629	BLUE
32	LOWER LEFT FLIPPER	Hold	J119-4 (RED-BLU)			Q69	J120-7		ORG-BLU			
33	UPPER RIGHT FLIPPER	Power	J119-6 (RED-VIO)		Q84		J120-6		YEL-VIO		FL-11630	RED
34	UPPER RIGHT FLIPPER	Hold	J119-6 (RED-VIO)			Q86	J120-4		ORG-VIO			
35	BALL LAUNCH RAMP	Power	J119-8 (RED-GRY)		Q81		J120-3		YEL-GRY		B-13522	YELLOW
36	NOT USED	Hold	J119-8 (RED-GRY)			Q83	J120-1		ORG-GRY			

### Motor Circuit

Sol No.	Function	Solenoid Type	Voltage Connection	Drive Gates	Drive Connections	Drive Wire Color	Device Part Number
37	WHEEL SPIN (CCW)	Low Power	J139-2	U3A U3B	J110-1	BRN-WHT	SEE MANUAL
38	WHEEL SPIN (CLOCK-WISE)	Low Power	J139-2	U3C U3D	J110-3	ORG-WHT	SEE MANUAL

### Auxiliary Circuit

Sol No.	Function	Solenoid Type	Voltage Connection	Drive Gates	Drive Connections	Drive Wire Color	Device Part Number
42	UPPER RIGHT 1 FLASHER	Flasher	J4-1	Q2	J4-2	BLU-BRN	#906
43	UPPER RIGHT 2 FLASHER	Flasher	J4-1	Q4	J4-3	BLU-RED	#906
44	UPPER RIGHT 3 FLASHER	Flasher	J4-1	Q6	J4-4	BLU-ORG	#906
45	UPPER PLAYFIELD RIGHT	Flasher	J4-1	Q8	J4-5	BLU-ORG	#906 (2)
46	UPPER PLAYFIELD LEFT	Flasher	J4-1	Q10	J4-7	BLU-GRN	#906
47	UPPER LEFT 1 FLASHER	Flasher	J4-1	Q12	J4-8	BLU-BLK	#906
48	UPPER LEFT 2 FLASHER	Flasher	J4-1	Q14	J4-9	BLU-VIO	#906
49	UPPER LEFT 3 FLASHER	Flasher	J4-1	Q16	J4-10	BLU-GRY	#906

## LAMP MATRIX

Column	1 Yellow-Brown J121-1 Q96	2 Yellow-Red J121-2 Q100	3 Yellow-Orange J121-3 Q95	4 Yellow-Black J121-4 Q99	5 Yellow-Green J121-5 Q94	6 Yellow-Blue J121-6 Q98	7 Yellow-Violet J121-7 Q93	8 Yellow-Grey J121-8 Q97
1 Red-Brown J125-1 Q104	OUTLANE EXTRA BALL	HOLE 5	HOLE 6	DRIVING RANGE	(K)ICK	4 STROKES	ADVANCE TRAP	SIDE RAMP DRIVE
2 Red-Black J125-2 Q108	KICKBACK	HOLE 4	HOLE 7	INCREASE GOLF CART	K(I)CK	3 STROKES	CENTER DRIVE	EXTRA BALL
3 Red-Orange J125-4 Q103	LOWER DRIVING RANGE	HOLE 3	HOLE 2	INCREASE BUZZ VALUE	KIC(C)K	2 STROKES	CENTER LOCK	MULTIBALL
4 Red-Yellow J125-5 Q107	SHOOT AGAIN	HIT BUD	HIT BUZZ	INCREASE BUD VALUE	KIC(K)	5 STROKES	GET T.N.T.	JACKPOT
5 Red-Green J125-6 Q102	SPECIAL	HOLE 1	HOLE 9	NEWTON DRIVE	SKILL SHOT	7 STROKES	CENTER RAISE GOFER	PUTT OUT
6 Red-Blue J125-7 Q106	WHEEL VALUE	2X	4X	COLLECT	RIGHT RAISE GOFER	6 STROKES	RIGHT SPINNER	TOP JET BUMPER
7 Red-Violet J125-8 Q101	JET LIGHTNING	CART PATH 2	CART PATH 4	RIP OFF	RIGHT RAMP LOCK	LEFT SPINNER	RIGHT LOOP DRIVE	MIDDLE JET BUMPER
8 Red-Grey J125-9 Q105	HOLE 8	5X CART PATH	3X	LEFT LOOP DRIVE	RIGHT RAMP DRIVE	TRAP READY	BOTTOM JET BUMPER	START BUTTON

J1XX = Power Driver Board

## SWITCH MATRIX

DEDICATED GROUNDED SWITCHES	Column	1 Green-Brown J206-1 U20-18	2 Green-Red J206-2 U20-17	3 Green-Orange J206-3 U20-16	4 Green-Yellow J206-4 U20-15	5 Green-Black J206-5 U20-14	6 Green-Blue J206-6 U20-13	7 Green-Violet J206-7 U20-12	8 Green-Grey J206-9 U20-11	FLIPPER GROUNDED SWITCHES
Orange-Brown J205-1 LEFT COIN CHUTE U17-5	1 White-Brown J208-1 U18-11	NOT USED	SLAM TILT	TROUGH EJECT	LEFT GOFER DOWN	LEFT SLING	LEFT SPINNER	LEFT CART PATH	K-I-C-K ADVANCE	Black-Green J208-13 Lower Right Flipper E.O.S.
Orange-Red J205-2 CENTER COIN CHUTE U17-7	2 White-Red J208-2 U18-9	LEFT RAMP MAKE	COIN DOOR CLOSED	TROUGH BALL 1	RIGHT GOFER DOWN	RIGHT SLING	RIGHT SPINNER	RIGHT CART PATH	(K)ICK	Blue-Violet J212-12 Lower Right Flipper Opto
Orange-Black J205-3 RIGHT COIN CHUTE U17-11	3 White-Orange J208-3 U18-5	START BUTTON	JET ADVANCE STANDUP	TROUGH BALL 2	NOT USED	TOP JET BUMPER	INNER WHEEL OPTO	RIGHT RAMP MAKE	(K)ICK	Black-Blue J208-12 Lower Left Flipper E.O.S.
Orange-Yellow J205-4 4TH COIN CHUTE U17-9	4 White-Yellow J208-4 U18-7	PLUMB BOB TILT	ALWAYS CLOSED	TROUGH BALL 3	PUTT OUT POPPER	MIDDLE JET BUMPER	OUTER WHEEL OPTO	GOLF CART	KI(C)K	Blue-Gray J212-11 Lower Left Flipper Opto
Orange-Green J205-6 Normal Function Srv Crdts	5 White-Green J208-5 U19-11	CENTER RAMP MAKE	UNDERGROUND PASS	TROUGH BALL 4	RIGHT POPPER JAM	BOTTOM JET BUMPER	LEFT GOFER 1	RIGHT GOFER 1	KIC(K)	Black-Violet J208-11 Upper Right Flipper E.O.S.
Orange-Blue J205-7 Normal Function Volume On	6 White-Blue J208-7 U19-9	LEFT OUTLANE	LEFT IN-LANE	TROUGH BALL 5	RIGHT POPPER	TOP SKILL SHOT	LEFT GOFER 2	RIGHT GOFER 2	CAPTIVE BALL	Black-Yellow J212-10 Upper Right Flipper Opto
Orange-Violet J205-8 Normal Function Volume Up	7 White-Violet J208-8 U19-5	RIGHT IN-LANE	RIGHT OUTLANE	TROUGH BALL 6	LEFT RAMP DOWN	MIDDLE SKILL SHOT	BEHIND LEFT GOFER	ADVANCE TRAP VALUE	NOT USED	Black-Gray J208-10 Upper Left Flipper E.O.S.
Orange-Grey J205-9 Normal Function Begin J2	8 White-Grey J208-9 U19-7	BALL SHOOTER	KICK BACK	JET POPPER	RIGHT RAMP DOWN	LOWER SKILL SHOT	HOLE-IN ONE MADE	SAND TRAP EJECT	NOT USED	Black-Blue J212-9 Upper Left Flipper Opto

J2XX = CPU Board = OPTO, TYPICALLY CLOSED